

P.P. Foot Valves Flange End

Drawing »

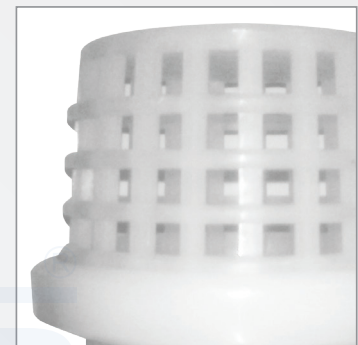
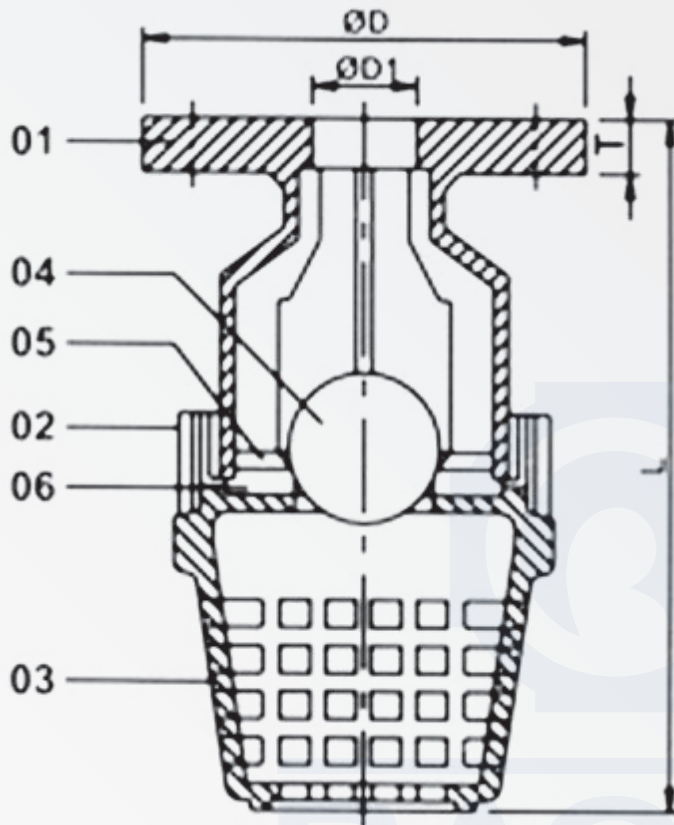

PP FOOT VALVE FE ($\pm 2\text{MM}$)					
Size		D	D1	L	T
IN	MM				
1"	25	120.0	26.0	170	18.0
1.1/2"	40	140.0	38.0	200	21.0
2"	50	160.0	54.0	210	23.0
2.1/2"	65	182.0	64.0	295	25.0
3"	80	200.0	77.0	295	26.0
4"	100	229.0	100.0	370	26.0

S. N.	Parts Name	Material
01	Top Body	Polypropylene
02	Bottom Body	Polypropylene
03	Strainer	Polypropylene
04	Ball	Polypropylene
05	Stop Ring	Polypropylene
06	Seat Ring	Neoprene/EPDM/VITON/PTFE

Note: (1) All Dimension are in mm
(2) Tolerance ± 3 mm
(3) 6" valves available on request