

# I. C. Three Way Ball Valves Screw End



## Technical Data

Design & Manufacturing Std: BS 5351 / API 602  
 Testing & inspection Std: API 598 / BS 5146  
 End Connections: BSP / NPT

Drawing »

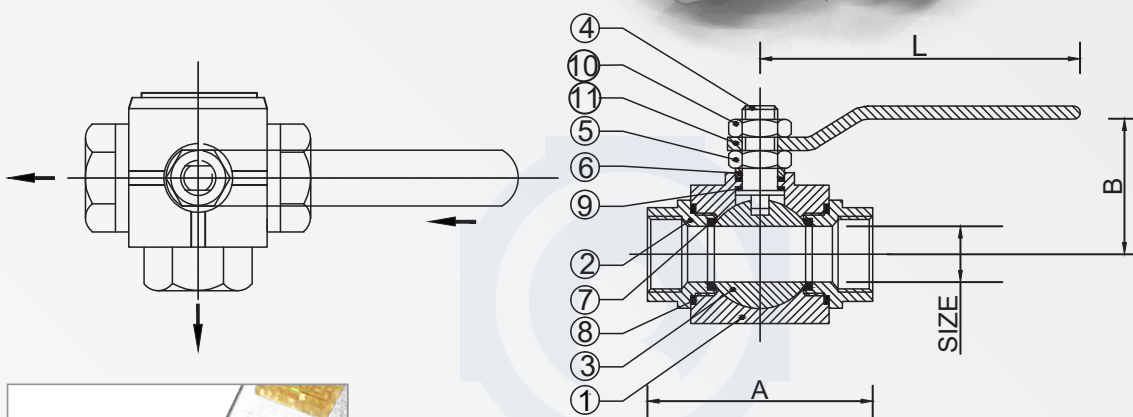

## PRIMARY SERVICE RATING & TEST PRESSURE

Class	Hydro Test Pressure		Max. Temp.
	Body	Seat	
150	425 PSI	300 PSI	180°C
Air Test - Seat 80 PSI ± PSI			

## I. C. THREE WAY BALL VALVE S/E

Size		A	B	L
Inch	M.M.			
1/2"	15	69	49	115
3/4"	20	80	53	135
1"	25	89	57	135
1.1/2"	40	140	86	170
2"	50	152	93	170

Sr. No.	Parts Name	Material	Qty
01	Body	ASTM A 351 Gr. CF8/CF8M/CF3/CF3M	1
02	Body Connector	ASTM A 351 Gr. CF8/CF8M/CF3/CF3M	3
03	Ball	AISI 304/316/304L/316L	1
04	Stem	AISI 304/316/304L/316L	1
05	Gland Nut	AISI 304/316/304L/316L	1
06	Gland Bush	AISI 202/304/316/304L/316L	1
07	Seat Ring	PTFE/GFT	4
08	Body Seal	PTFE/GFT	3
09	Steam Seal	PTFE/GFT	2
10	Lock Nut	AISI 304/316/304L/316L	2
11	Lever	M.S./S.S. 202/304/316	1

Note: (1) All Dimension are in mm  
 (2) Tolerance  $\pm 3$  mm  
 (3) Available in  
 'T' Port & 'L' Port Ball Design

Application

