

C. S. "Y" Strainer Flange End

Technical Data

Face To Face:	As per DIN ND-40 Type/ANSI B 16.10
End Connections:	Flange as per ANSI B 16.5
Shell Wall Thickness:	ANSI B 16.34

Drawing »

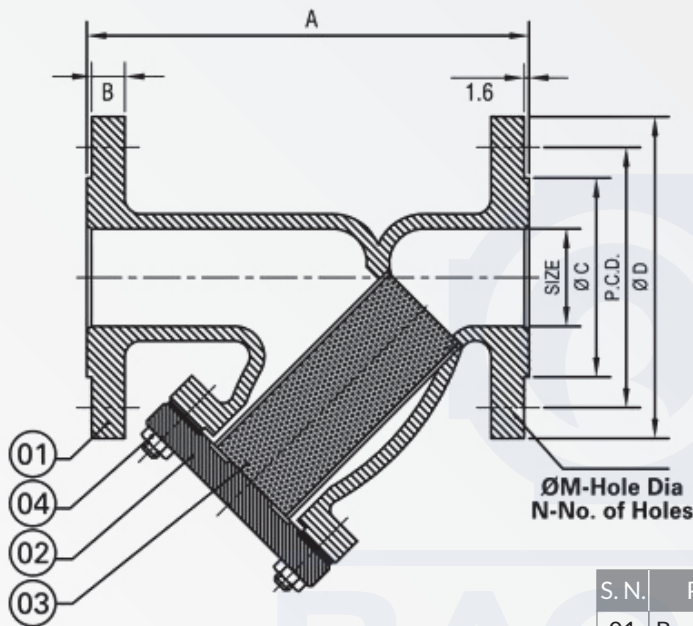

Hydraulic Test Pressure	
Body	10 Kg/cm ²

S. N.	Parts Name	Material	Qty
01	Body	ASTMA 216 Gr. WCB	1
02	Cover	ASTMA 216 Gr. WCB	1
03	Screen	S.S./304	1
04	Cover Stud & Nut	M.S.	-

CLASS 150#							
Size	A	B	ØC	ØD	ØM	N	P.C.D.
25	127	11	51	108	16	4	79
40	165	14	73	127	16	4	98.5
50	203	16	92	152	19	4	120.5
65	216	17.5	105	178	19	4	140
80	241	19	127	190.5	19	4	152.4
100	292	24	157	229	22	8	190.5
150	406	25	216	279	22	8	241
200	495	28.5	270	343	22	8	298.4
250	622	30	324	406	25	12	362
300	698	30	382	483	25	12	432

ND - 40							
Size	A	B	ØC	ØD	ØM	N	P.C.D.
25	160	18	68	115	14	4	85
40	200	18	88	150	18	4	110
50	230	20	102	165	18	4	125
65	290	22	122	185	18	8	145
80	310	24	138	200	18	8	160
100	350	24	162	235	23	8	190
150	480	28	218	300	27	8	250
200	600	35	285	375	30	12	320
250	730	38	345	450	30	12	385

Note: (1) All Dimension are in mm
(2) Tolerance ± 3 mm

Application

