

Needle Valves

Technical Data

Design and Manufacturing Std: As per Mfr's Std.

Testing and Inspection Std: BS5146

End Connection: Screwed BSP



Drawing »

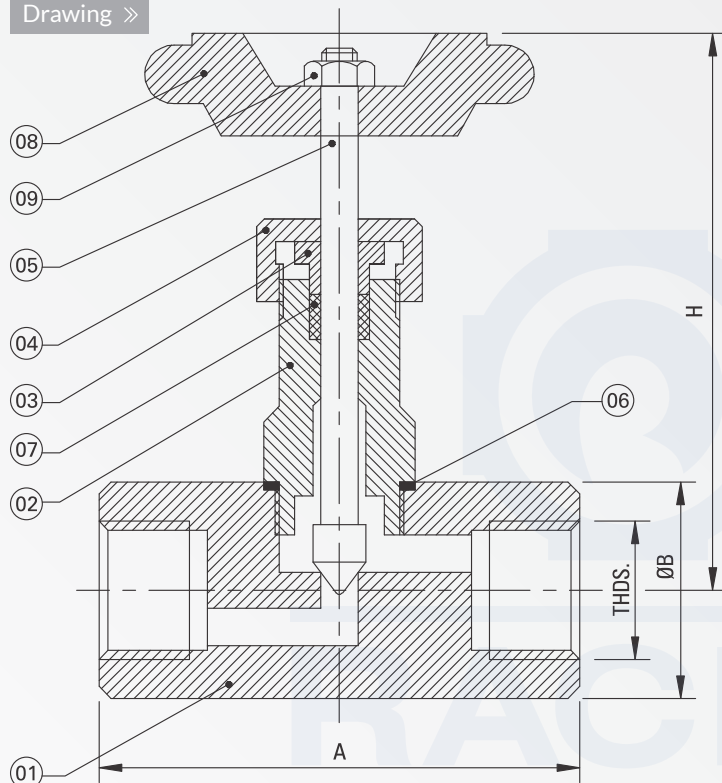

NEEDLE VALVE				
Size NB	A	THDS-BSP	H	ØB
8/10	50	1/4" - 3/8"	70	27
15	50	1/2"	70	31
20	63	3/4"	90	39
25	70	1"	95	45
40	85	1.1/2"	120	65
50	90	2"	130	75

PRIMARY SERVICE RATING & TEST PRESSURE	
Hydro Test Pressure	
Round Body	Square Body
1000 PSI	3000 PSI

S. N.	Parts Name	Material	Qty
01	Body	S.S. 202/S.S. 304/S.S. 316	1
02	Bonnet	S.S. 202/S.S. 304/S.S. 316	1
03	Gland	S.S. 202/S.S. 304/S.S. 316	1
04	Gland Nut	S.S. 202/S.S. 304/S.S. 316	1
05	Stem	S.S. 202/S.S. 304/S.S. 316	1
06	Body Gasket	PTFE	-
07	Gland Packing	PTFE	1
08	Hand Wheel	Bakelite	1
09	Hand Wheel Nut	M.S.	1

Note: (1) All Dimension are in mm
 (2) Tolerance ± 3 mm
 (3) 6000 PSI and 10000 PSI available on request

