

I. C. Globe Valves Screw End

Technical Data

Design & Manufacturing Std:	ANSI B 16.34 / API 600
Testing & inspection Std:	API 598
Face To Face:	As per ANSI B 16.10
End Connections:	Screw - BSP/NPT

Drawing »

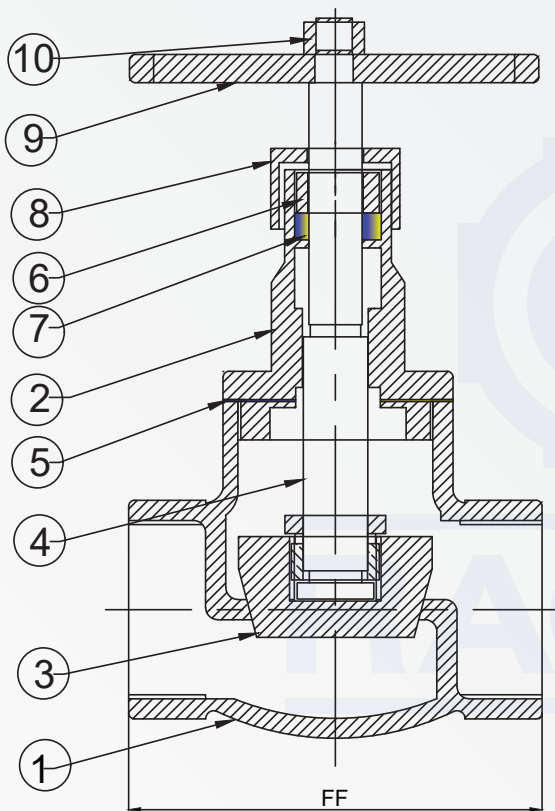

PRIMARY SERVICE RATING & TEST PRESSURE

Class	Hydro Test Pressure		Max. Temp.
	Body	Seat	
150	425 PSI	300 PSI	300°C
Air Test - Seat 80 PSI ± PSI			

I C S/E GLOBE VALVE		
Size		FF
Inch	M.M.	
1/2"	15	61
3/4"	20	69
1"	25	81
1.1/2"	40	101
2"	50	122

S. N.	Parts Name	Material	Qty
01	Body	ASTM A351 GR. CF8/CF8M/CF3/CF3M	1
02	Bonnet	ASTM A351 GR. CF8/CF8M/CF3/CF3M	1
03	Globe	AISI 304/316/304L/316L	1
04	Stem	AISI 304/316/304L/316L	1
05	Body Sealent Ring	PTFE	1
06	Gland	SS 202/304/316	1
07	Gland Packing	PTFE/Grafoil	-
08	Bonnet Nut	AISI 304/316/304L/316L	1
09	Hand Wheel	Cast Iron/M.S.	1
10	Hand Wheel Nut	SS 202/304/316	1

Note: (1) All Dimension are in mm
(2) Tolerance ± 3 mm

