

C. I. Foot Valves Flange End 150#

Technical Data

Design and Manufacturing Std: Generally Conforming to IS 4038/BS-1

End Connection: BS 4504 (PN-16)

Drawing »

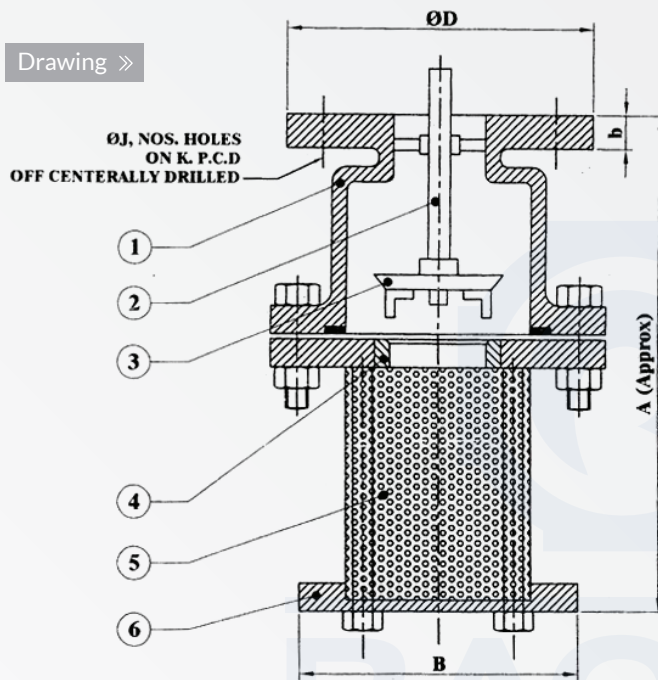

C. I. FOOT VALVE FE 150#							
Size	A	B	ØD	b	ØJ	N	K P.C.D.
40	-	-	133.3	16	4	19	-
50	180	100	152.4	18	4	19	114.3
65	187	115	165.1	18	4	19	127
80	210	136	184.1	21	4	19	146
100	245	165	216	22	4	19	177.8
125	273	207	254	22.5	8	19	209.5
150	320	223	279.4	23	8	23	235
200	400	280	336.5	24.5	8	23	292
250	485	320	406.4	26	8	23	355.6
300	555	378	457.2	27.5	12	23	406.4
350	660.5	495.3	527	28	12	23	470
400	673.1	558.8	577.8	30	12	28	520.7
450	735	605	641.3	31.5	12	28	584.2
500	840	665	704.8	33	16	28	641.3

S. N.	Parts Name	Material	Qty
01	Body	BS 1452 GR 220	01
02	Valve Guide	Brass/MS/S.S.	01
03	Valve	G.M. BS 1400 LG 2	01
04	Seat	G.M. BS 1400 LG 2	01
05	Screen	Galvanized Iron	01
06	Plate	BS 1452 GR 220	01

TEST PRESSURE

Testing	Body	Seat
Hydraulic	215 PSI	140 PSI

Note: (1) All Dimension are in mm
(2) Tolerance ± 3 mm