

# Forge Steel Ball Valves Screw End

## Technical Data

Design & Manufacturing Std: BS 5351 / API 602  
 Testing & inspection Std: API 598 / BS 5146  
 End Connections: Screw : BSP / NPT / Socket Weld  
 / Reduce Bore

## Drawing »

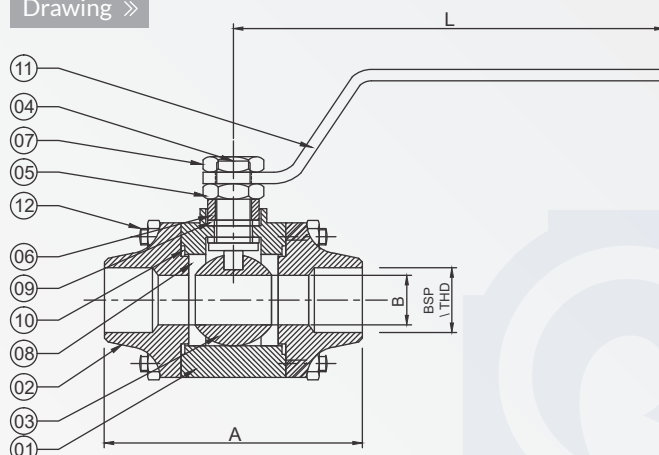

Sr. No.	Parts Name	Material	Qty
01	Body	ASTMA - 105, A-182 (F 304 & F 316)	1
02	Body Connector	ASTMA - 105, A-182 (F 304 & F 316)	2
03	Ball	AISI 304, 316	1
04	Stem	AISI 304, 316	1
05	Gland Nut	AISI 304, 316, M.S.	1
06	Gland Bush	S.S. 202/304/316	2
07	Lock Nut	AISI 304, 316, M.S.	1
08	Seat Ring	PTFE/GFT	2
09	Stem Seal	PTFE/GFT	2
10	Body Sealant Ring	PTFE/GFT	2
11	Lever	M.S. / S.S.	1
12	Stud & Nuts	193 B7 / S.S.	4

## PRIMARY SERVICE RATING & TEST PRESSURE

Class	Hydro Test Pressure		Max. Temp.
	Body	Seat	
800	1100 PSI	800 PSI	180°C

## F.S. BALL VALVES 3PC S/E

SIZE		DIMENSION		
Inch	M.M.	A	B	L
1/2"	15	85	12.5	125
3/4"	20	85	12.5	125
1"	25	105	18	155
1.1/2"	40	125	32	230
2"	50	130	38	230

Note: (1) All Dimension are in mm.  
 (2) Tolerance  $\pm 3$  mm  
 (3) Socket weld also available  
 (4) Full bore valves also available

Application

